

Article by George Viola BSEE from American Plating Power

Senior Sales Engineer at American Plating Power and Graduate of the University of Hartford with a degree in Electrical Engineering. 30 years of experience in the rectifier and metal finishing industry, including design, applications, and sales.



The Technical History of the Metal Finishing Rectifier

Upon reflection, while I prepare to write this article, it dawned on me that I am about to turn 55 and have been climbing in and out of rectifiers for nearly 50 years, literally. Although I was curious, I did not realize what rectifiers were or what they did for a number of years. I soon came to realize that rectifiers were in my blood and I was not getting away from them any time soon. You see, my uncle Jim had started this little company in the Bronx called Rapid Electric. My Dad was the treasurer and every Saturday I went to work with him. I would climb into these big enclosures, get in the way and ask lots of questions. I stand back now and realize that I have witnessed the evolution of this equipment first hand.

Rectifiers by definition, convert AC or Alternating Current to DC or Direct Current. This means that the AC sine wave that the utility gives us alternates from positive to negative at 60 times per second or 60Hz. A rectifier therefore converts this to DC by not allowing the negative or positive to pass depending on the direction the device is in the circuit. Figure 1 below shows a sine wave from the utility. Figure 2 depicts the effect of the sine wave passing through a diode from negative to positive or Anode to Cathode

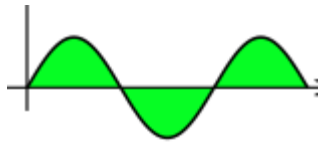

Figure 1



Figure 2

Prior to my personal experience with the generation of DC power there were the Motor Generator sets (MG) of the early days of plating, but I start with these because they were so big, heavy, inefficient and relatively expensive at the time. The MG set consisted of an AC motor directly coupled to a DC generator. This system supplied isolation from

the AC grid while providing a reliable source of DC. Control and regulation was limited and slow. Efficiency was around 50% mainly due to friction and windage losses. Later designs used a one-piece armature that shared both the motor and generator coils. The commutator would be on one end of the armature for the motor side and the generator would have its own commutator on the opposite side. This allowed for the ability to produce MG sets that were smaller and lighter with an improvement in efficiency without the exposed drive shaft.

The Selenium rectifier was invented in 1933. It was mainly used in power supplies and radio equipment. These steel plates were coated with nickel and selenium. The plates were then stacked together to achieve the desired amount of voltage and current to be produced. Each plate is unidirectional and allows current to flow in one direction. Each plate was about 18V in the reverse direction making them the first power rectifier diode. These plates also served as the heat sinks for the first diodes. The plating industry began using them in the 1960's in conjunction with the saturable core reactor until diodes became reliable and economical in the late 60's.



Typical MG set with 3 phase motor and DC output, photo courtesy of Google Images.

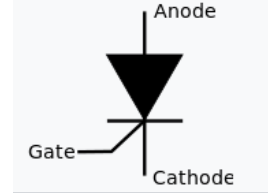

Photo of a multi plate Selenium stack courtesy of Wikipedia

A Saturable Core Reactor is a magnetic device that is used in series with a main transformer to control the amount of current flow. The main transformer in this rectifier design provides isolation from the main input voltage and reduces the voltage to a desired output for electroplating. This is similar to the main transformer in active SCR type rectifier design. In a saturable core reactor, the magnetic core is saturated by the introduction of a small DC current in the field winding. As the DC current is increased to the field winding and core, the inductance is decreased proportionally allowing more current to flow through the device thus regulating the output. This gives the ability to regulate large current flow using a small amount of DC current. Typically, the small DC control was regulated by a single-phase rectifier with stud type SCR's that were available in those days along with a simple circuit board. Because of the robustness of this design, many of these rectifiers are still running today in various shops across the country. The rectifiers are in the 75% efficiency range. They are also larger, heavier and more expensive to build. This product was phased out once power semiconductors became large enough to carry the current that the metal finishing industry demanded.

The Silicon controlled rectifier device was first developed in Bell Laboratories in 1956. It was not until 1957 that GE developed the SCR for commercial use. SCR devices are passive devices that can only

conduct current in one direction, like a diode. But an SCR can be told when to “turn on” by the use of a “gate.” A small amount of current is applied to a gate and the SCR would start to conduct current in the one direction. It is important to note that an SCR only needs a short pulse of current through the gate to turn on and cannot be turned off until the current crosses zero or the voltage across the device is zero or shorted. This is an important consideration when we talk about IGBT’s later. In today’s modern SCR power supply, there are many configurations of SCR’s and transformer combinations to produce DC power. There are primary and secondary SCR



Symbol for an SCR, positive current flows from anode to cathode when the gate is pulsed.

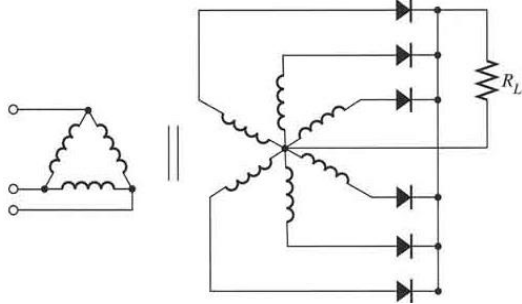

Drawing above shows a typical Delta primary main rectifier transformer with a six-phase star secondary.

The output of the diodes in this case are positive and the center of the star is negative. Drawing courtesy of Google Images

circuits in several circuit configurations for each. They both have advantages and disadvantages depending on rating, current or voltage, harmonics and device availability. The most popular by volume circuit in the plating industry would be the secondary SCR with the circuit connection called a six-phase star.

This is where the main three phase transformer isolates the AC line voltage and reduces the voltage to the specifically what it needed for the SCR to produce the desired plating voltage. In this case, the SCR’s are on the secondary side of the main transformer. On the secondary side, there are six windings, two for each phase of the primary. On one side of each of the six windings would be an SCR in the forward direction. The other side of the windings are all tied together. This will be the negative output and the output sides of the SCR will be the positive. When the SCR’s are fully phased on then the voltage and current would be at full output and the waveform would look like figure 3. When the SCR’s are gated back to reduce current or voltage then the output waveform would look like figure 4.

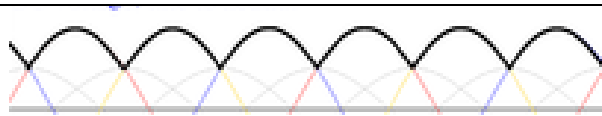

Figure 3

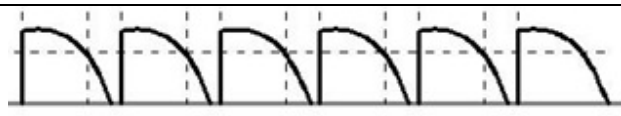
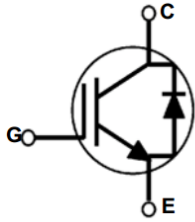

Figure 4

SCR rectifiers for the metal finishing industry were the most popular between the 1970’s to the 2000’s. During this time, IGBT technology was growing in device size and reliability. Today, IGBT devices are taking over as the semiconductor of choice for use in metal finishing rectifiers in the small to medium power range. Some disadvantages of SCR technology are the high ripple content of the DC output, (without a filter) high harmonics reflected back to the power line and lower efficiency at partial load.



Symbol for an IGBT is courtesy of completpowerelectronics.com

Modern Switchmode rectifiers use the Isolated Gate Bipolar Transistor also known as the IGBT. IGBTs initially appeared in the late 1980s and early 1990s.

This was the first generation of the device and with these high power ratings, began the switchmode revolution for use in rectifiers within the metal finishing industry. The initial devices were prone to failure from

heat and control issues. They have since evolved into a very stable, reliable and widely used device in the metal finishing, drive and inverter industries. IGBT's are not rectifiers. They are merely switches that can switch on and off at a very fast rate. SCR's can only be turned on while IGBT's can be turned both on and off. The Switchmode rectifier takes the AC input from the utility and immediately rectifies the power. The power is then sent into what is called a chopper section where the IGBT converts the DC into very high frequency pulses on the order of 20 KHz. The pulse width determines the output voltage and current regulation that the user desires by control potentiometers or other means. This high frequency set of pulses is then sent through a rectifier and transformer that produces the desired output. The important part here is the frequency. The higher the frequency the proportionally smaller magnetics become along with transformers filters, motors etc. This is why a Switchmode Power Supply is so compact compared to an equally sized SCR rectifier. The advantages of Switchmode technology in an equivalent power rating are that the rectifier is smaller and lighter by design, higher efficiency at lower outputs and inherently low ripple. Figure 5 shows a typical Switchmode power circuit.

The evolution continues with newer, higher speed devices and improved circuit designs along with more thorough manufacturing procedures. With these new devices, DC, DC pulsing and pulse reverse will continue to improve as manufacturing process change and demand different waveforms with higher reliability. The evolution of the technology continues, and rectifiers are still in my blood.

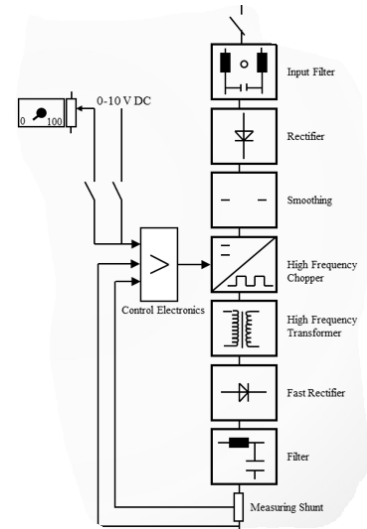

Typical Switchmode typology courtesy of [Munk](#).

