

Modified Push-Pull Ventilation For Energy Efficiency in Process Design

By Kevin D. Bomboy, P.E.

Energy-efficient design has been emphasized for process and building systems for many years. When the U.S. Department of Energy (DOE) assigned STV Group, Pottstown, PA, to a plating facility design project, energy conservation was a main objective of the design team. In this application, the primary means of reducing energy use was by decreasing the ventilation air requirements of the plating tanks. The objective was achieved through a modified push-pull ventilation system, a form of tank cover/air limiting device. The energy reduction lowered operating costs at the facility by 77 percent.

The DOE required a new electroplating and technology support facility to replace a 30-year-old, antiquated plant. A state-of-the-art facility was required to meet DOE's plating and deplating needs with precision.

Through intensive studies, the design team determined that two features were necessary to meet DOE's goals:

1. The use of an automated plating line where the precision required for the parts plating is controlled automatically and not subject to human error (also providing a vehicle to operate the modified push-pull system).
2. An exhaust system that will decrease energy use.

Full Push-Pull—

The Conventional System

Uncovered plating tanks have been the industry standard. The tanks remain open with operator protection provided by either an exhaust, or combination supply-exhaust (push-pull), ventilation system (Fig. 1). This creates a curtain of air across the tank tops, which prevents contaminants from escaping. Contaminants are

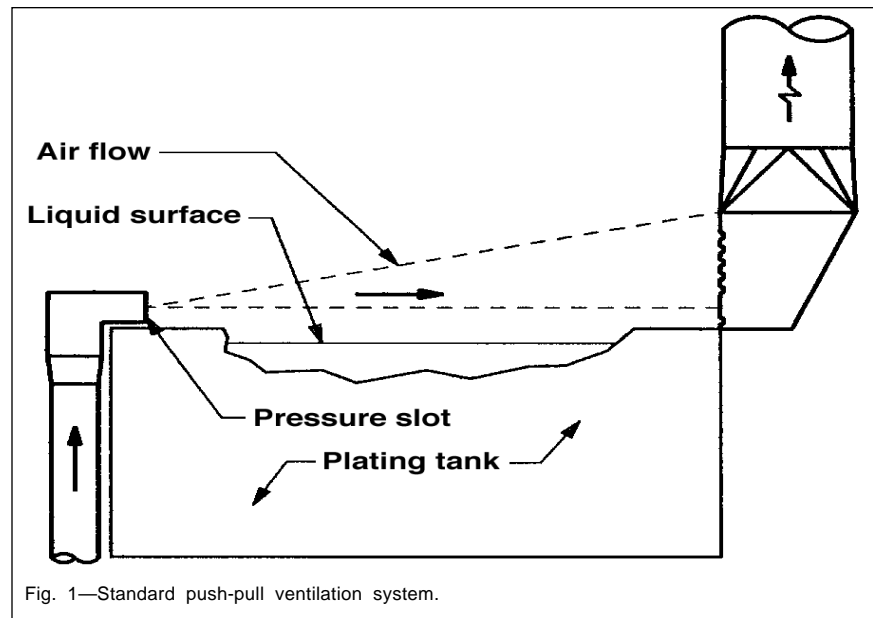

captured in the exhaust system and removed by water scrubbers prior to the air being discharged into the atmosphere (Fig. 2 and 3).

This system typically operates continuously, pulling a large quantity of conditioned air from the building. For the DOE building, a full push-pull ventilation system would exhaust about 100–150 ft³ of air per min from every ft² of plating tank for a building total of 100,000 ft³/min. Operating the system would cost DOE an estimated \$159,185 per year.

Despite its high energy usage, a conventional push-pull ventilation system has several desirable aspects that are incorporated into the modified push-pull system:

- The system has maximum flexibility with no obstructions over the tank.
- The operator can easily see the tank contents.
- The system provides the maximum operating protection from plating fumes.

- The system is simple with no moving parts.

Despite its advantages, there are aspects of a conventional push-pull ventilation system that the design team felt were undesirable for a modified push-pull system.

- High energy use through tank ventilation air.
- The possibility of chemicals from one tank dripping into the other tanks during transfer of parts along the plating line.
- High energy use for heating the plating tanks.
- Rapid evaporation of some chemicals from uncovered tanks.
- Greater possibility for operating personnel coming in contact with the chemicals in the tanks.

The Modified Push-Pull System

The design strategy was to develop a modified push-pull system that provides the operator the safety and visibility of a full push-pull system during plating, but reduces energy

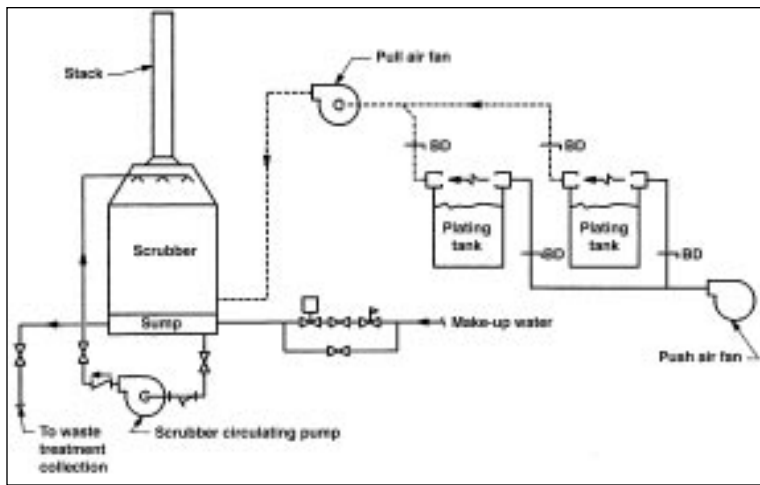

Fig. 2—Typical plating exhaust system.

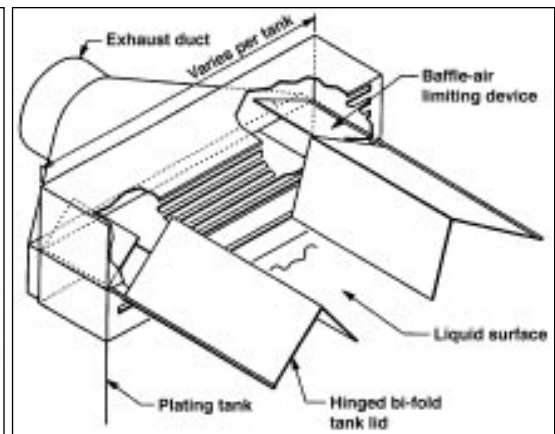

Fig. 3—Pull side mechanism. The baffle that reduces airflow operates on the same shaft that opens and closes the lid cover of the plating tank.

consumption during periods when tanks are empty. The team developed a covered tank system that can be opened during plating and closed during idle periods. The automated hoist and computer system activates the opening and closing of covers so that only two tank lids per plating line can be open simultaneously—the tank from which the part is being removed and the tank the part will enter next. Airflow from the plating tanks is reduced when the tank is covered.

A cover was developed that utilizes the tank lid as an air-limiting device. Baffles affixed to the lid partially block the pull and completely block the push duct openings serving the tank's ventilation system (Fig. 3). When the lid is closed, a reduced air flow occurs, but it still holds the tank at a negative pressure, preventing hazardous fumes from escaping. A programmable controller directs the machine that moves the hoist from tank to tank and controls the lids in proper sequence.

Several features differentiate the modified push-pull from the conventional system:

- When all the tank lids are closed, the push fan is deactivated or the air is bypassed from the tanks to ensure a negative pressure develops in the tank.
- The design utilizes side shields on the tanks to prevent cross-drafts between tanks. The shields are the same height as the top of the push and pull ductwork, so that when the lid closes on the tank it contacts on all four sides.

- All lids are automatically controlled to prevent operators from leaving lids open or opening too many lids at one time.
- Airflow velocities in exhaust and supply duct mains should be kept at the lower suggested boundary to minimize fluctuations of airflow with the opening and closing of lids.
- Baffles for push and pull air slots are adjustable to fine-tune the air quantities and flow characteristics of the system.
- Either a variable volume exhaust fan or a bypass damper will be used to account for the varying airflows caused by lids opening and closing.
- All materials used in the modified push-pull design must resist corrosion from the specific chemicals in the tanks.

Operating cost of the modified push-pull system is estimated to be \$36,175 per year, 77 percent less than a conventional system.

Results

Covering plating tanks and using a full push-pull airflow only when the tanks are in use reduces the total air quantity to about 25 percent of the standard push-pull airflow system. The reduction in air exhausted from the building directly affects the make-up air quantity within the building. In the case of the DOE building, ventilation air was reduced from 100,000 ft³ to 25,000 ft³, making air conditioning feasible for the facility.

The energy required to heat plating tanks is also decreased significantly by covering the tank. Fan energy

consumption was reduced because of the lower airflow quantity. Capital outlay was decreased because the new system allows a reduction in the size of support equipment, such as ductwork air handlers and scrubbers.

A simple payback of less than six months was calculated for the DOE project. The estimated capital cost of the conventional push-pull system is \$450,100, while the modified push-pull was estimated to cost \$488,620. The difference in capital costs—\$38,520—divided by the difference in operational costs—\$119,390—results in a simple payback of 0.32 years. The energy savings outweighs the additional capital cost of the modified push-pull system.

The modified push-pull system slightly restricts the operator, but drastically reduces energy use, compared to the standard full push-pull system. Covered tanks reduce health risks by keeping a barrier between the operator and tank chemicals. The modified push-pull system has a higher initial cost but, through operational cost savings, has a relatively short payback period. *P&SF*

About the Author

Kevin D. Bomboy, P.E., is a project engineer with STV Group, 11 Robinson St., Pottstown, PA 19464. He was responsible for the development of the modified push-pull system described in this article. He graduated from Pennsylvania State University with a BS in architectural engineering and is a registered professional engineer in six states.